

## Lagerliste HB 500 Messerschneiden

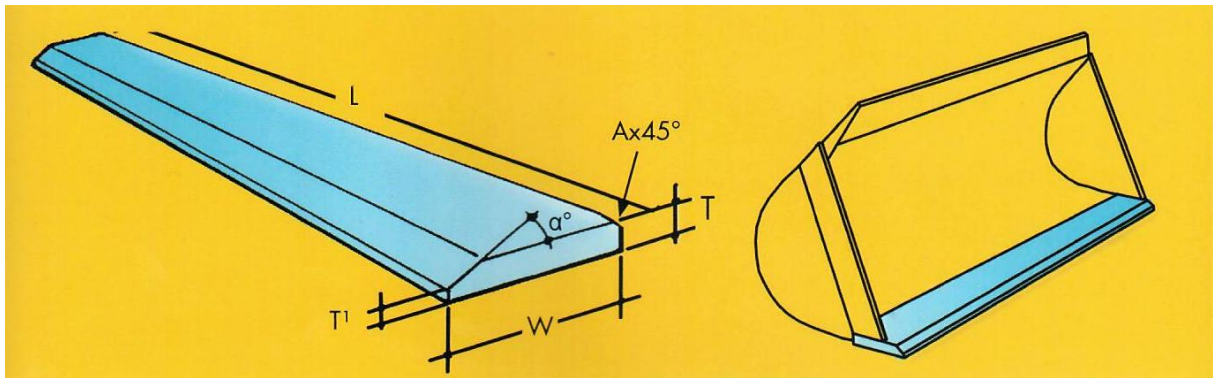

Art. Nr.	T mm	W mm	A mm	L mm	$\alpha$ Grad	T1 mm	kg/m
12-100	12	100	4	6050	25	4	8.9
16-100	16	100	5	6050	25	4	11.5
16-150	16	150	5	6050	25	4	17.5
20-150	20	150	5	6050	25	6	21.8
20-200	20	200	5	6050	25	6	29.7
25-200	25	200	5	6050	25	8	36.7
25-250	25	250	5	6050	25	8	46.5
30-200	30	200	8	6050	25	10	43.5
30-250	30	250	8	6050	25	10	55.3
30-300	30	300	8	6050	25	10	66.6
35-270	35	270	9	6050	25	12	69.4
35-300	35	300	9	6050	25	12	77.3
40-300	40	300	10	6050	25	14	86.4
50-300	50	300	11	6050	25	17	107.6